

CAT. NO.	"L"	HARDWARE
1SBH18CL	18	NO
1SBH18CLH	18	YES
1SBH21CL	21	NO
1SBH21CLH	21	YES
1SBH24CL	24	NO
1SBH24CLH	24	YES
1SBH30CL	30	NO
1SBH30CLH	30	YES

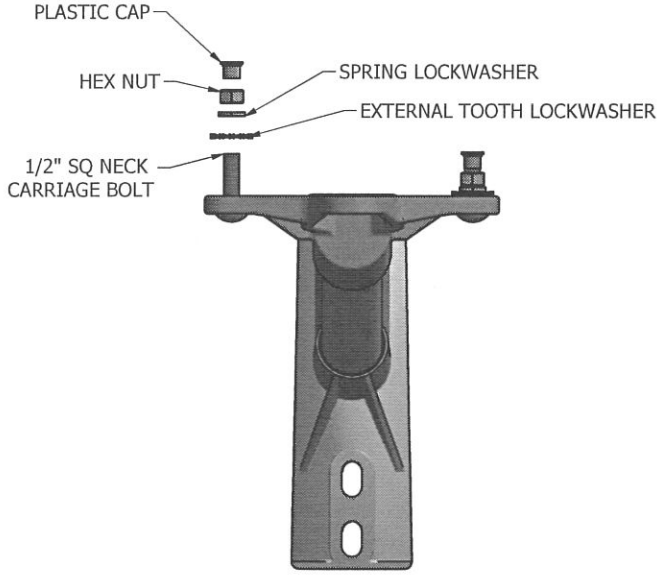
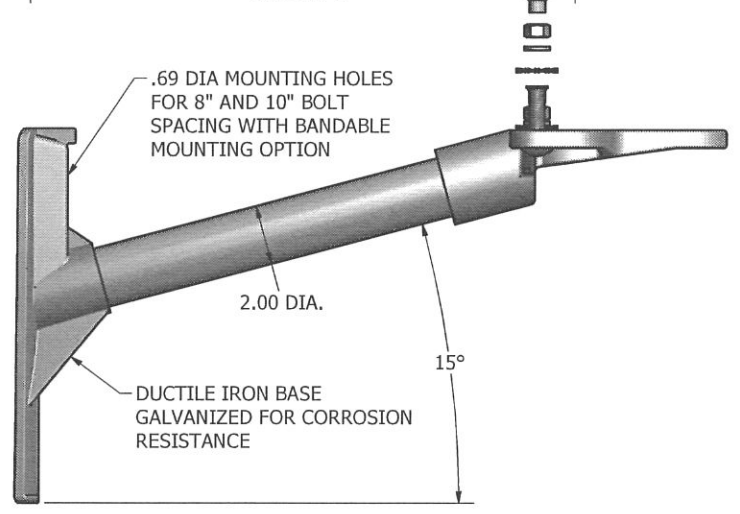

-NOTES-

1. CAPTIVE HARDWARE FOR MOUNTING ACCESSORIES IS OPTIONAL. IF THIS HARDWARE IS DESIRED, ADD SUFFIX "H" TO THE CATALOG NUMBER SHOWN IN THE TABLE.

THIS SYMBOL IDENTIFIES CRITICAL FEATURES

CHANCE.		HUBBELL POWER SYSTEMS, Inc.	
CONFIDENTIAL: THIS DRAWING AND ITS CONTENTS ARE CONFIDENTIAL AND THE EXCLUSIVE PROPERTY OF HUBBELL POWER SYSTEMS. NO PUBLICATION, DISTRIBUTION OR COPIES MAY BE MADE WITHOUT THE WRITTEN CONSENT OF HUBBELL POWER SYSTEMS. HUBBELL POWER SYSTEMS UNPUBLISHED ALL RIGHTS RESERVED UNDER THE COPYRIGHT LAWS		TITLE CLOVERLEAF STANDOFF	
		SIZE B	DWG NO. SA1SBH18CL
DO NOT SCALE THIS DRAWING	DRN BY RAM	DATE 12/10/13	SHEET 1 OF 1